

FORM 3 ENDTERM 2 EXAMS

MATHEMATICS

PAPER 1

TIME: 2 1/2 HOURS

NAME..... ADM NO:.....

SIGN..... DATE;.....

SECTION I(50 marks)

Answer all the questions in this section in the spaces provided.

1. Evaluate:

(3mks)

$$\frac{1}{2} \left(\frac{3}{5} + \frac{1}{4} \left(\frac{7}{3} - \frac{3}{7} \right) \right) \text{ of } 1\frac{1}{2} \div 5$$

2. A triangle has vertices A(2,5), B(1,-2) and C(-5,1). Determine;

a) The equation of line BC.

(2mks)

b) The equation of perpendicular line from A to BC.

(2mks)

FOR MARKING SCHEMES CALL/WHATSAPP 0705525657

3. The shaded region in the figure below shows an area swept out on a flat windscreen by a wiper. Calculate the area of the region. Take $\pi = 3.142$. (3mks)

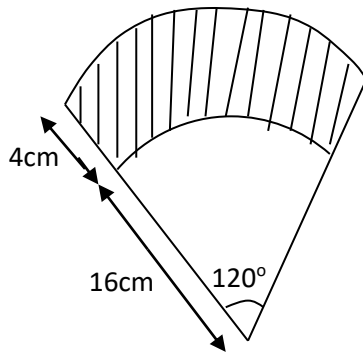

4. A piece of metal has a volume of 20cm^3 and a mass of 300g. Calculate the density of the metal in kg/m^3 . (3mks)

5. List the integral values of x which satisfy the inequalities below. (3mks)

$$2x + 21 > 15 - 2x \geq x + 6$$

6. Janet is a saleslady earning a basic salary of Kshs. 20,000 per month and a commission of 8% for the sales in excess of Kshs. 100,000. If in January 2010 she earned a total of Kshs. 48,000 in salaries and commissions. Determine the amount of sales. She made in that month. (3mks)

7. The interior angle of a regular polygon is 108° larger than the exterior angle. Find the number of sides of the polygon. (3mks)

8. Given that $\cos A = \frac{5}{13}$ and angle A is acute. Find the value of $2\tan A + 3\sin A$ without calculators. (3mks)

9. Without using a calculator evaluate:

(2mks)

$$\frac{-9 + (-7) \times (-8) - (-5)}{-2 + (-6) \div 3 \times 6}$$

10. Solve for x in the equation below.

(3mks)

$$\frac{6x - 4}{3} - \frac{2x - 1}{2} = \frac{6 - 5x}{6}$$

11. Calculate the area of the trapezium show below.

(3mks)

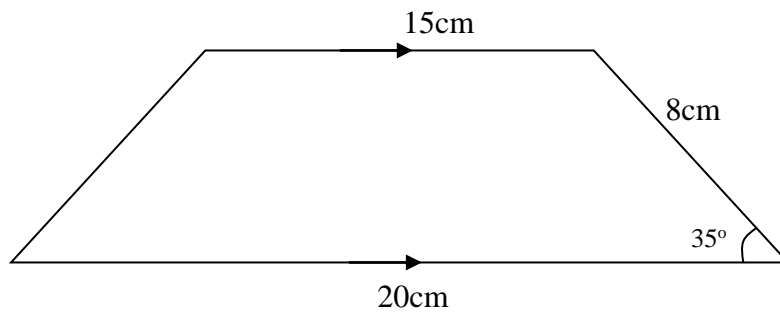

12. Solve the simultaneous equation.

(4mks)

$$\begin{aligned}x^2 + y^2 &= 26 \\x + y &= 4\end{aligned}$$

13. Express 72 and 125 as products of their prime factors. (2mks)

14. A service vehicle left town P for town Q at 1000hrs had a puncture after travelling for 4 hrs 20 mins. Fixing a new tyre took 33 minutes. The vehicle then travelled for 1 hr 20mins to reach town Q. At what time did it arrive in 12 hour clock system? (3mks)

15. A tourist visited Kenya with 2500 US dollars and changed the US dollars into Kenya shillings at a local bank in Kenya when the exchange rates at the time were as follows:

	<i>Buying</i>	<i>Selling</i>
1 US dollar	shs.78.45	shs. 78.55
1 Sterling Pound	shs.120.25	shs. 120.45

a) How much did he get in Kenya shillings? (2mks)

b) While in Kenya he used shs. 80,000 and after his stay he converted the remaining amount into Sterling pounds. Calculate to 2 decimal places the Sterling pounds that he got. (2mks)

16. Use logarithms tables to evaluate: (4mks)

$$\sqrt[3]{\frac{497 \times 9.84}{5.24 \times 7.65}}$$

SECTION II (50 marks)

Answer any five questions in this section in the spaces provided.

17. A motorist left Embu for Nairobi a distance of 240km at 8:00 a.m. and travelled at average speed of 90km/hr. Another motorist left Nairobi for Embu at 8:30a.m and travelled at 100km/hr. Find;
- a) The time they met. (3mks)

- b) How far they met from Nairobi. (3mks)

- c) The time of the day each motorist arrived at his destination. (4mks)

FOR MARKING SCHEMES CALL/WHATSAPP 0705525657

18. A farmer has a rectangular farm which measures 100m by 80m. The farmer intends to fence the plot using post at intervals of 4m apart leaving a gate of 4m. Also he will use four strands of barbed wire. Each post cost shs. 125 and wire is sold at rolls of 60m costing 1,500/=. Calculate;

a) The number of post he will use. (2mks)

b) The total length of the barbed wire. (2mks)

c) The total cost of fencing the farm if the cost of the gate is 8,000/= and labour is shs. 1,500. (3mks)

d) The farmer wishes to subdivide further the farm into square plot. Find the maximum area of each plot. (2mks)

FOR MARKING SCHEMES CALL/WHATSAPP 0705525657

19. The parents of a certain mixed school decided to buy a school van worth Kshs 900,000. Each student was to contribute the same amount of money. 50 students were transferred from the school as a result each of the remaining students had to pay kshs.600 more.

a) Find the original number of the students in the school. (5mks)

b) Find the percentage change in contributions per student. (3mks)

c) If the ratio of boys to girls in the school was 11:7, find the amount of money contributed by boys alone. ((2mks)

20. The figure below shows two circles of radii 8cm and 6cm with centres O_1 and O_2 respectively. The circles intersect at points A and B. The lines O_1O_2 and AB are perpendicular to each other. If the common chord is 9cm; (Take $\pi=3.142$.)

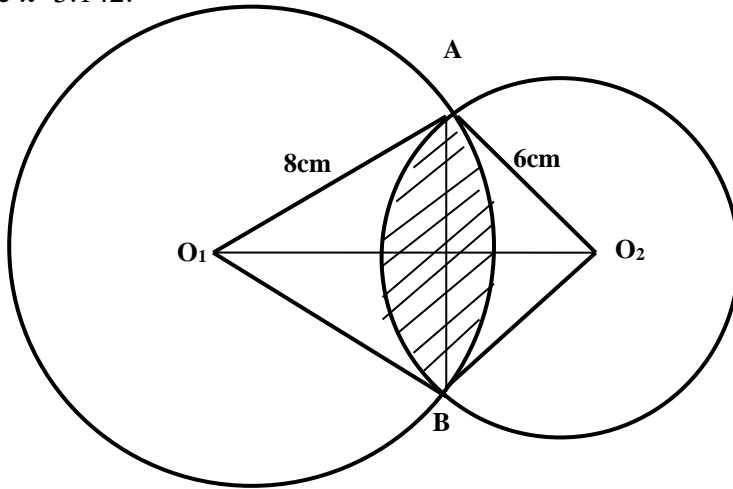

Calculate to 4.s.f.

a) Angle AO_1B

(2mks)

b) Angle AO_2B

(2mks)

c) Area of the shaded region.

(6mks)

21. A village water tank is in the form of a frustum of a cone of height 3.2m. The top and bottom radii of 18m and 24m respectively as shown below.

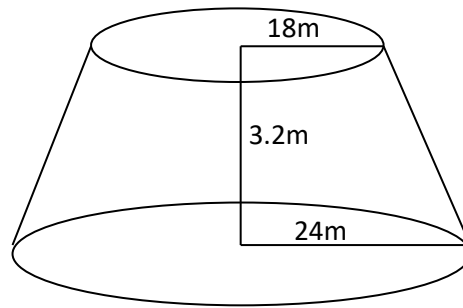

- a. Calculate;
- The surface area of the tank excluding the bottom. (4mks)
 - The capacity of the tank in litres. (3mks)
- b. 15 families each having 15 members use the water tank and each person uses 65 litres daily. How long will it take for the full tank to be emptied? (3mks)

22. Measurements of a maize field using baseline XY were recorded as shown below in metres

	Y	
	240	
To R 160	190	
	180	75 To Q
	150	50 To P
To S 100	120	
	100	100 To N
To T 30	50	
	20	20 To M
	X	

a) Show the map of the maize field by scale drawing. Take 1cm rep 20m.

(4mks)

b) Find the area of the field in hectares.

(4mks)

c) If the cost of one hectare is Kshs. 65,000, find the total cost of the maize field.

(2mks)

FOR MARKING SCHEMES CALL/WHATSAPP 0705525657

23. Using a ruler and pair of compass only construct the following.

a) Triangle XYZ where XY is 6cm and angle XYZ is 135° and YZ=7cm. Measure XZ.

(3mks)

b) Drop a perpendicular from Z to meet line XY at K. measure YK.

(3mks)

c) Bisect line XY and let the bisector meet line XZ at Q.

(2mks)

d) Join Q to Y and measure angle XQY.

(2mks)

24. Complete the table for the function.

a) $y=1 - 2x - 3x^2$ in the range $-3 \leq x \leq 3$

(2mks)

x	-3	-2	-1	0	1	2	3
$-3x^2$	-27		-3	0		-12	
$-2x$				0			-6

FOR MARKING SCHEMES CALL/WHATSAPP 0705525657

1	1	1	1	1	1	1	1
y	-20			1		-15	

b) Use the table above to draw a graph of $y=1 - 2x - 3x^2$ on the graph provided. (4mks)

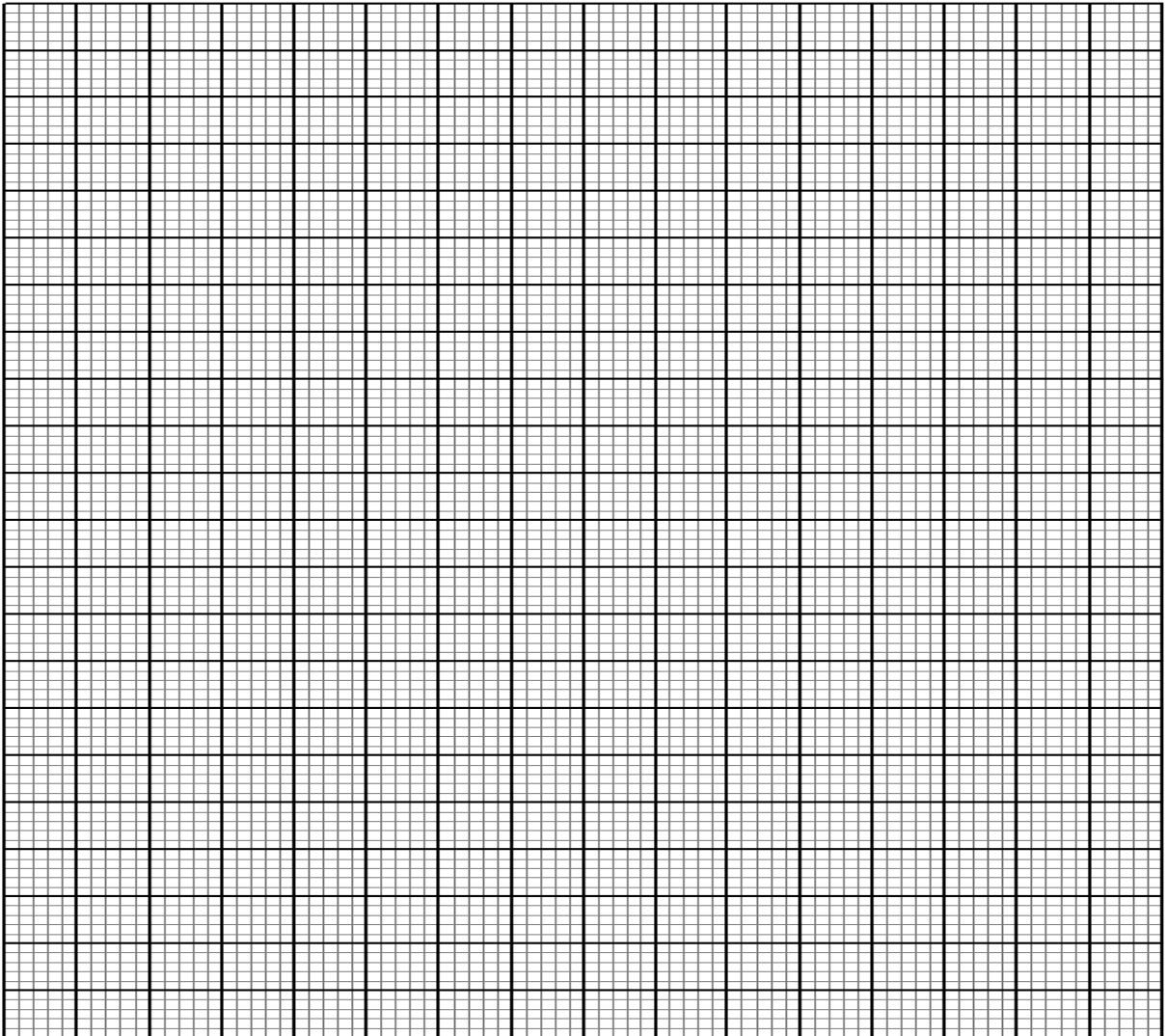

c) Use the graph in (b) above to solve;

i. $1 - 2x - 3x^2 = 0$ (2mks)

ii. $2 - 5x - 3x^2 = 0$ (2mks)